

# CETONI

## **CE** QMIX Q- Hardware Manual

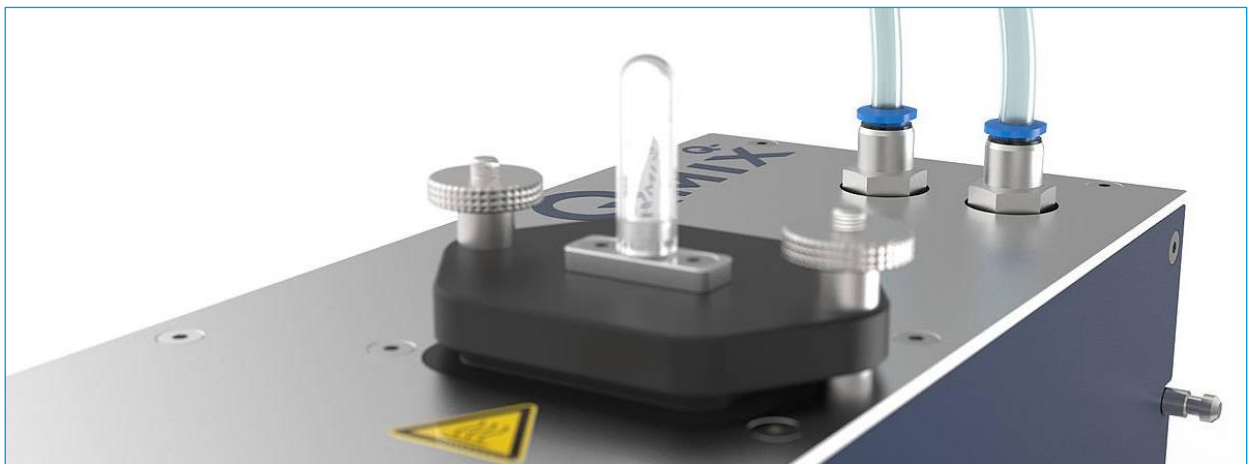

ORIGINAL INSTRUCTIONS 1.00 – AUGUST 2017

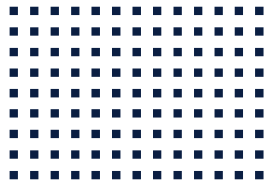

CETONI GmbH  
Wiesenring 6  
07554 Korbussen  
Germany

**T** +49 (0) 36602 338-0

**F** +49 (0) 36602 338-11

**E** [info@cetoni.de](mailto:info@cetoni.de)

[www.cetoni.de](http://www.cetoni.de)

# Software License

The software and the accompanying documentation are protected by copyright. By installing the software, you agree to the terms of the license agreement.

## License Agreement

CETONI GmbH grants the buyer the simple non-exclusive and non-transferable license right to use the software on a single computer or networked computer system (LAN). Copying or any other reproduction of parts or the entire software as well as mixing and connecting with other software is expressly prohibited. For backup purposes, the customer may make a single copy of the software (backup). CETONI GmbH reserves the right to change, further develop, improve or replace the software with a new version. CETONI is under no obligation to inform the buyer about changes, new and further developments as well as improvements or to make them available to him. A legally binding assurance of certain properties is not given. CETONI is not liable for damages, unless the damage was caused by intent or gross negligence on the side of CETONI GmbH or its vicarious agents and assistants. Any liability for indirect as well as incidental and consequential damages is excluded.

The information and data contained in these documents may be changed without prior notice. No part of these documents may be reproduced or transmitted for any purpose whatsoever without the express written permission of CETONI GmbH, regardless of the way in which or by what means - electronic or mechanical - this is done. The GTC of CETONI GmbH apply. Any agreements deviating from these terms and conditions must be made in writing.

Copyright © CETONI GmbH - Automation and Microsystems. All rights reserved. WINDOWS is a registered trademark of Microsoft Corporation. The WINDOWS logo is a registered trademark ™ of Microsoft Corporation

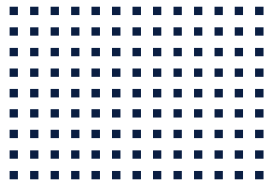

# 1 Overviews & Directories

## 1.1 Content

1	Overviews & Directories	5
1.1	Content	5
1.2	Revision History	6
2	Scope of Delivery	7
3	Technical Data	8
3.1	Environment	8
3.2	General Data	8
3.3	Electrical Data	8
3.4	Interfaces	8
4	Application Purpose	9
4.1	General Description of the Device	9
4.2	Intended Use	9
4.3	Reasonably Foreseeable Faulty Application	9
4.4	Safety Advice	9
5	Transport and Storage	10
6	Operation	11
6.1	The Cooling Function	11
6.2	Mounting the Chip Holder	12
6.3	Mounting the High Temperature Mixer	14
7	Maintenance and Care	16

## 1.2 Revision History

<b>REV</b>	<b>DATUM</b>	<b>ÄNDERUNG</b>
1.00	31.08.2017	Creation

## 2 Scope of Delivery

The following items should be included:

### QMIX Q- MODULE

- Chip holder or mixer as ordered



### CD-ROM QMIXELEMENTS WITH:

- Device drivers for the USB interface
- QmixElements Software
- Qmix SDK (optional)
- Qmix device configuration



### HARDWARE MANUAL



# 3 Technical Data

## 3.1 Environment

<b>OPERATING TEMPERATURE</b>	0°C ~ 40°C
<b>STORAGE TEMPERATURE</b>	-20°C ~ 75°C
<b>OPERATING HUMIDITY</b>	20% ~ 90%, non-condensing
<b>STORAGE HUMIDITY</b>	20% ~ 90%, non-condensing

## 3.2 General Data

<b>DIMENSIONS (L X W X H)</b>	310 x 98 x 90 mm
<b>WEIGHT</b>	2,1 kg
<b>MAXIMUM HEATING TEMPERATURE</b>	100°C
<b>MINIMUM COOLING TEMPERATURE</b>	See 6.1

## 3.3 Electrical Data

<b>SUPPLY VOLTAGE</b>	24 VDC
<b>POWER CONSUMPTION</b>	80 W max.

## 3.4 Interfaces

<b>MOUNT FOR TWO CHIP HOLDERS</b>	
<b>TWO PUSH-IN FITTINGS</b>	For tubing with 6 mm outer diameter



# 4 Application Purpose

## 4.1 General Description of the Device

The Qmix Q- module with tube coil is a part of the Qmix micro reaction and analysis system. It allows the cooling and heating of microfluidic chips.

## 4.2 Intended Use

The Qmix Q- module is used to perform microfluidic reactions under defined temperature conditions. It is intended only to be used in a Qmix micro reaction system from CETONI GmbH. The application is usually carried out in laboratory-like rooms.

## 4.3 Reasonably Foreseeable Faulty Application

A use for applications distinct from the intended purpose can lead to dangerous situations and is to be omitted.



**CAUTION.** The unit must not be used as a medical device or for medical purposes!

## 4.4 Safety Advice

For the safe operation of Qmix Q- module it is necessary to observe the safety measures from the general section of the manual for the Qmix micro reaction system.



**IMPORTANT.** Please read this manual, the general part for the Qmix system, as well as the related software manual carefully and completely before putting your Qmix Q- module into operation.

# 5 Transport and Storage

Please do not lift or transport the modules when they are plugged together. Transportation of plugged-together devices is only allowed in the original packaging.

Use the original packaging for transportation or shipping of the module.

Concerning the storage conditions, please observe the data from chapter “Technical data”.



**CAUTION.** Risk of damaging the device. Do not transport the modules plugged-together.



**ATTENTION.** Transportation, storage or operation of the modules below 0°C with water in the fluid passages may cause damage to the module.

# 6 Operation

The Qmix Q- module offers a coolable as well as heatable tempering surface. Chip holders for microfluidic chips and mixers can be mounted on this tempering surface. The assembly of chip holders or mixers as well as the details of the cooling function are described in the following chapters. The software operation is explained in the corresponding software manual.



## 6.1 The Cooling Function

The maximum heating temperature is 100°C. The minimum temperature depends on many factors such as room temperature, flow rate and the reaction. On average, it is about 30 K below room temperature. In order to achieve the lowest possible temperatures, a free air flow through the unit must be possible. Therefore, pay attention to free ventilation slots.

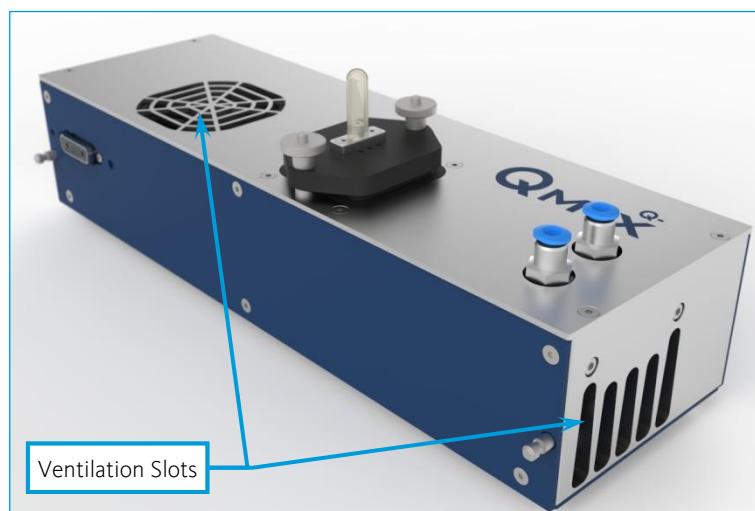

If the lowest temperature that can be achieved with air cooling does not meet your requirements, it is possible to support the cooling of the unit with an externally cooled liquid.

To do this, insert two tubes with an outer diameter of 6 mm into the connections on the unit and pump the coolant through them. The flow direction is arbitrary. To loosen the tubes later, press down the blue collar and pull out the tube.

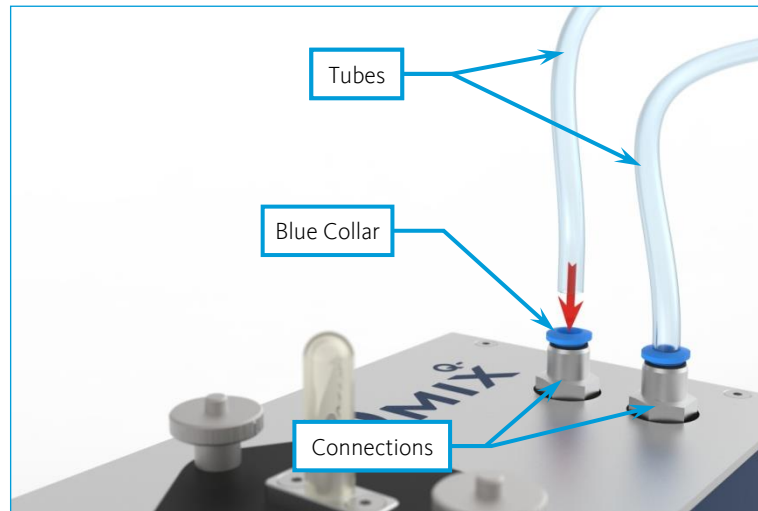

For example, tap water or ice water can be used as cooling liquid. Other liquids are also possible if they are compatible with NBR seals.

## 6.2 Mounting the Chip Holder

Each chip holder is individually designed to fit your chip layout. The following instructions are for chips whose connections are simple holes on one of the big flats. Flanged PTFE tubes are pressed on the connections of the chip. O-Rings behind the flange of the tube serve as a preload of the connection and as a compensation of tolerances.



**ATTENTION.** Check the chemical resistance of the wetted parts (chip and tubing) against the used chemicals before using the device.



**ATTENTION.** The chip holder is suitable for a maximum operating pressure of 10 bar.

Proceed as follows to insert a chip into the chip holder:

- (1)** Cut the tubes of the inputs and outputs so that they extend to the previous or subsequent interfaces.

- (2) Flange one end of the tube. The diameter of the flange should be about 3-4mm. A tool kit to make the flanges can be purchased from CETONI. Try to produce a flange as even as possible, to achieve a good sealing effect.
- (3) Thread an O-ring on the tube and plug it through one of the connecting holes of the chip holder from the inside. Press the O-ring into the corresponding groove of the chip holder.

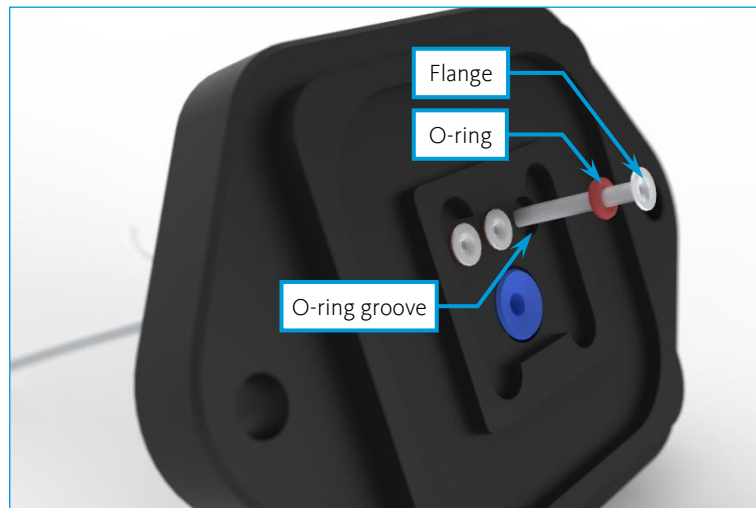

- (4) Compress the rubber cap on the top side of the chip holder and insert the chip so that the connection openings of the chip and the flanged tubes align. Press the chip down on the suction cup and then release the rubber cap. The chip is now fixed and you can mount the chip holder onto the Qmix Q- module.



**IMPORTANT.** Moisten the suction cup or the chip to improve the suction effect.

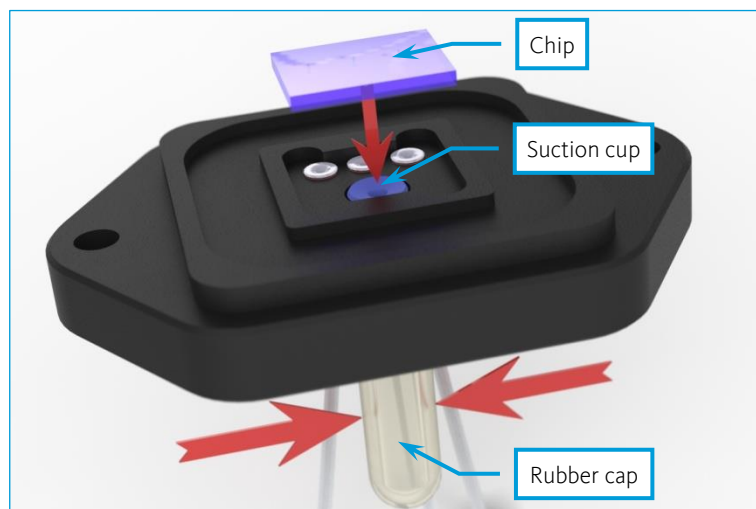

- (5) Mount the chip holder on the Qmix Q- module. For this, remove the two knurled nuts from the locating bolts. Then slide on the chip holder onto the bolts and reassemble the knurled nuts. Tighten the nuts alternating and equally until they are finger-tight.

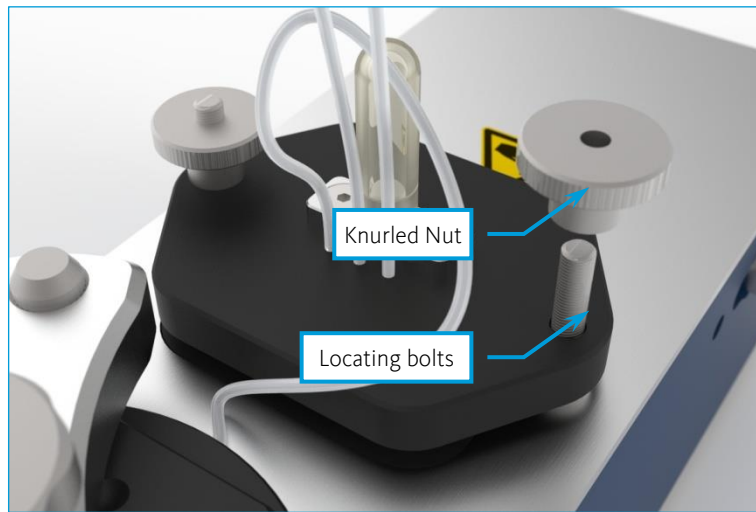

**CAUTION.** The chip holder can become very hot during operation. Do not touch it during operation and let it cool down before you carry out any assembly work.



**ATTENTION.** After connecting, check the tightness of all fluidic connections on a regular basis.

## 6.3 Mounting the High Temperature Mixer

Mount the mixer on the Qmix Q- module. For this, remove the two knurled nuts from the locating bolts and place the lower insulation on the device as shown in the picture. Then slide the mixer onto the bolts and reassemble the knurled nuts. Tighten the nuts alternating and equally until they are finger-tight.

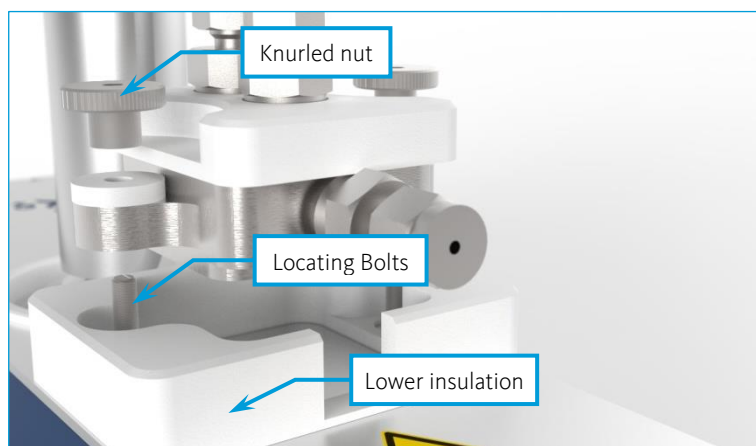



**CAUTION.** The mixer can become very hot during operation. Do not touch it during operation and let it cool down before you carry out any assembly work.

Screw-in fittings with a Swagelok® tube fitting are used for the fluidic connection. They are suitable for using capillaries made from metal (e.g. stainless steel, titanium) and plastic (e.g. PTFE, PEEK). Please refer to information provided by the respective manufacturer with respect to maximum pressure.

For the assembly and disassembly of the fittings you need a 9/16"-open-end wrench. Place the stainless steel ring in the tapped hole before mounting the fittings. Then screw in the fittings and tighten them to a torque of about 45 Nm.



**ATTENTION.** Clamp the Mixer in a vice to exchange the fittings. The following picture shows how this should be done. The mountings on the devices only serve for fixation and are not designed for the forces occurring during fitting exchange. Tighten the union nuts in a vice as well, if possible.

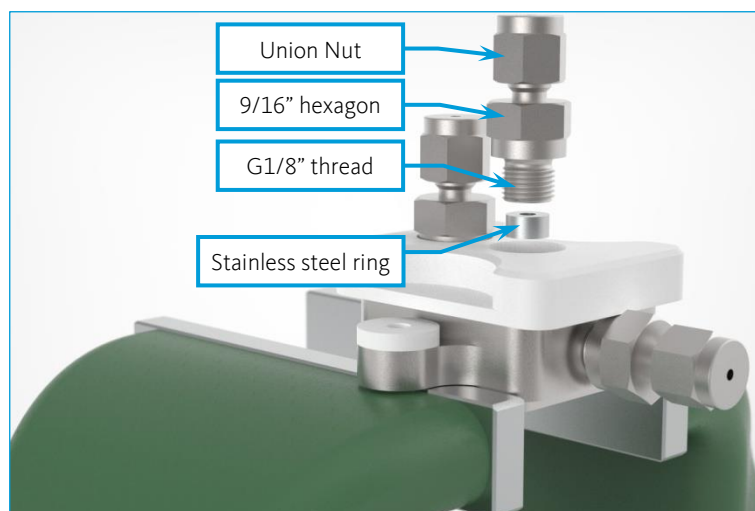

Depending on the type of tube fitting, capillaries with an external diameter of 1/16" or 1/8" can be used. For the Assembly or Disassembly of the tube fittings of the 1/16" version, you need a 5/16" open-end wrench and for the 1/8" version you need a 7/16" open-end wrench.



**ATTENTION.** Make sure that the capillary tubes or hoses, you want to use, are suitable for the expected temperatures and pressures. Check the tightness of all fluidic connections after connecting and on a regular basis.

# 7 Maintenance and Care

If used in accordance with intended purpose, the device is maintenance-free. Should there be a failure despite this, which you cannot eliminate yourself, or which requires opening the device, please contact CETONI GmbH to coordinate further actions. The device may only be opened by CETONI GmbH or thereby authorized service staff. Otherwise the warranty and guarantee claims are void.

Software-related troubles are dealt with in the Software Manual.

For cleaning it please rub the surface gently with a soft, damp cloth. The cloth must not be wet, so that no fluency can trickle into the device. In case of a heavier soiling you can also use a little bit of detergent or alcohol.