

# CETONI

## CE NEMIX Hardware Manual Syringe Stirrer

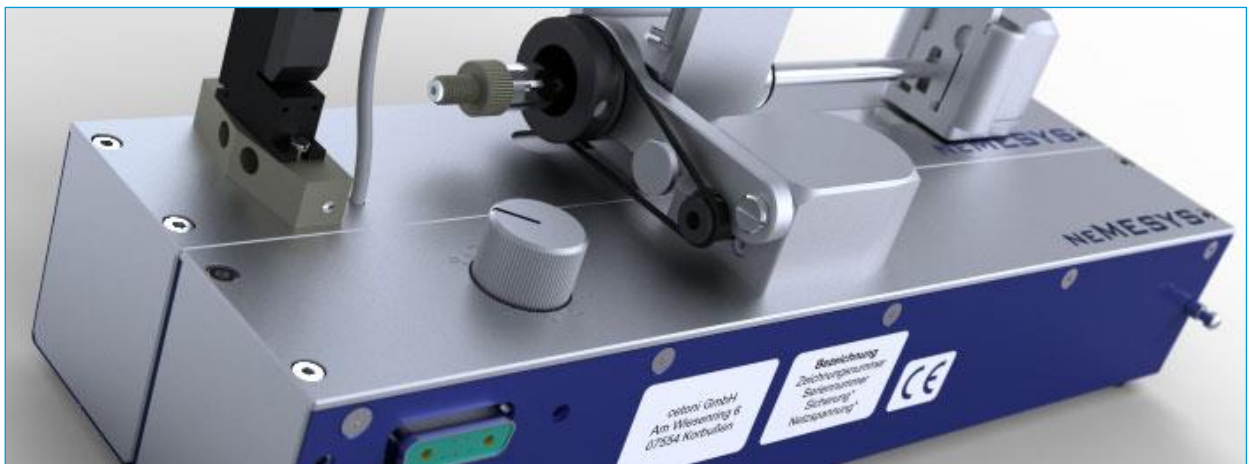

ORIGINAL INSTRUCTIONS 1.03 – MARCH 2016

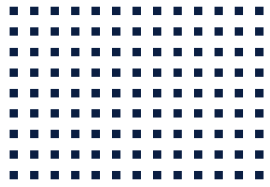

CETONI GmbH  
Wiesenring 6  
07554 Korbussen  
Germany

**T** +49 (0) 36602 338-0

**F** +49 (0) 36602 338-11

**E** [info@cetoni.de](mailto:info@cetoni.de)

[www.cetoni.de](http://www.cetoni.de)

# Software License

The software and the documents provided are protected by copyright. Installation declares your acceptance of the conditions of the licensing contract.

## License Agreement

CETONI GmbH grants the purchaser the non-exclusive and non-transferable license to use the software on a stand-alone computer or respectively a networked computer system (LAN). It is expressly forbidden to copy or duplicate the software in part or in whole in any way. The same applies to mixing and combining the software with other software. The purchaser is entitled to make one single copy of the software for security purposes (backup). CETONI GmbH retains the right to amend, further develop, improve, or through a new development; replace the software. CETONI is under no obligation to inform the purchaser of amendments, new/further developments or improvements, or to make these available. A legally binding assurance of certain features is not given. CETONI is not liable for damages unless the damages are as a result of wilful intent or gross negligence on the part of CETONI GmbH or its employees. Any liability for indirect, collateral, or consequential damages is excluded.

The information and data contained in this documentation can be amended without notice. The reproduction, distribution and utilization of this document as well as the communication of its contents to others without explicit authorization is prohibited. Offenders will be held liable for the payment of damages.

All rights reserved in the event of the grant of a patent, utility model or design.

The general terms and conditions of CETONI GmbH apply. Alternative agreements must be in written form.

Copyright © CETONI GmbH – Automatisierung und Mikrosysteme. All rights reserved

CETONI® and neMESYS® are registered trademarks of the CETONI GmbH

WINDOWS is a registered trademark of the Microsoft Corporation.

The Windows logo is a registered trade mark ™ of the Microsoft Corporation.

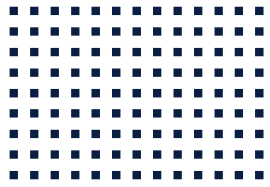

# 1 Overviews and Indexes

## 1.1 Content

1	Overviews and Indexes	5
1.1	Content	5
1.2	Change History	6
2	Safety Instructions	7
2.1	Symbols and Keywords	7
2.2	Standards and Guidelines	7
3	Basic Information	8
3.1	Foreword	8
3.2	Application Purpose	8
3.2.1	General Description of the Device	8
3.2.2	Intended Use	8
3.2.3	Reasonably Foreseeable Faulty Application	8
3.2.4	Safety Advice	9
3.2.5	Measures for Safe Operation	9
3.2.6	Safety Devices on the Unit	10
3.2.7	Condition of the Unit	10
3.3	Warranty and Liability	10
3.4	Scope of Supply	11
4	Technical Specifications	13
4.1	Stirring Module	13
4.1.1	Mechanical Data	13
4.1.2	Electrical Data	13
4.1.3	Environment	14
4.1.4	Dimensions	14
4.2	Stirrer Element	15

4.2.1	Technical Data	15
4.3	Stirring Speed	16
5	Transportation and Storage	17
5.1	Transportation	17
5.2	Storage	17
6	Start-Up	18
6.1	Adding a Stirring Module	18
6.2	Removing the Stirring Module	19
7	Operation	20
7.1	Mounting and Demounting of the Stirrer	20
7.2	Syringe Clamping	21
8	Maintenance and Care	27
8.1	Troubleshooting	27
8.2	Cleaning	27
9	Disposal	28

## 1.2 Change History

REV	DATE	CHANGE
1.01	08.02.2011	First version of neMIX hardware manual – new model
1.02	11.03.2016	Revision Guide Design

# 2 Safety Instructions

## 2.1 Symbols and Keywords

The following symbols are used in this handbook and are designed to aid your navigation through this document:



**HINT.** Describes practical tips and useful information to facilitate the handling of the software.



**IMPORTANT.** Signifies important hints and other useful information that may not result in potentially dangerous or harmful situations.



**CAUTION.** Identifies a potentially harmful situation. Failure to avert this situation may result in damage to the product or anything in its proximity.



**ATTENTION.** Indicates a potentially dangerous situation. Failure to avert this situation may result in light or minor injuries or property damage.

## 2.2 Standards and Guidelines



This unit has been tested and registered in accordance with the limit values for industrial units; class 1, group B. CETONI GmbH declares under its sole responsibility, that the product complies with the relevant provisions stated on the last page.

Operation underlies the following conditions:

1. The unit is not allowed to emit damaging radiation
2. The unit must be able to process damaging radiation, including radiation of a nature that could lead to an undesirable operation.

The product fulfils limit values in accordance with EN55011, class 1, group B. The unit underwent and passed tests in accordance with DIN EN 61000-4-4 (Burst) and DIN EN 61000-4-5 (Surge).

# 3 Basic Information

## 3.1 Foreword

Thank you for deciding to purchase a CETONI product. We would like to support you with this handbook as far as possible in your interaction with the neMIX Syringe stirrer together with the neMESYS syringe pump system. We are directly available for any questions or suggestions that you may have.

You may not use the neMESYS Syringe Stirrer before you have carefully read and understood this handbook. We wish you much success in your work with the neMIX Syringe Stirrer.

## 3.2 Application Purpose

### 3.2.1 General Description of the Device

The device processes suspensions that should be homogeneously stirred to prevent the sedimentation of the particles. Under these conditions you can feed chemical and biological processes with reagents with nearly constant particle concentrations over a certain amount of time.

### 3.2.2 Intended Use

The neMIX Syringe Stirrer is used for stirring / mixing reagents in the inner of a syringe.

Application usually takes place in laboratory-like rooms.

### 3.2.3 Reasonably Foreseeable Faulty Application

A use for applications distinct from the intended purpose can lead to dangerous situations and is to be omitted.



**CAUTION.** The unit must not be used as a medical device or for medical purposes.



## 3.2.4 Safety Advice

The safety of the user and a failure-free operation of the unit are only assured if original parts are used. Only original accessories may be used. Warranty claims will not be accepted for damage due to the use of alien accessories or expendables.

The unit has been developed and constructed in such a way as to largely exclude hazards due to its intended use. Nevertheless, you should observe the following security measures in order to exclude any remaining hazards.

- CETONI GmbH points out the responsibilities of the operator for the operation of the device. The laws and regulations of the place of installation must be observed while operating the unit! To ensure a safe work routine, operators and users must assume responsibility for adhering to regulations.
- Before operating the unit, the user must at all times ensure the operational reliability and the adequate and orderly condition of the unit.
- The user must be familiar with the operation of the unit.
- The unit and pipes must be checked for damage before operation. Damaged pipes and inputs must be replaced immediately.
- Cables must be laid in a way that avoids any risk of stumbling.
- Moving parts must not be touched whilst the unit is in operation. There is a risk of crushing!
- The usage of the device in explosive atmosphere or with explosive materials is prohibited!

## 3.2.5 Measures for Safe Operation

### 3.2.5.1 ELECTROMAGNETIC EMISSIONS

The neMESYS dosing system is intended for use in any type of facility, including living quarters, and those that are connected to a public mains network that supplies buildings used for living purposes.

### 3.2.5.2 ELECTROSTATIC DISCHARGE

Floors should consist of wood, concrete, or ceramic tiles. If the flooring consists of a synthetic material; the relative humidity must be at least 30%.

### 3.2.5.3 ELECTRIC DISTURBANCES

The quality of the supply voltage should be to the standard of a typical business or hospital environment.

#### **3.2.5.4 MAGNETIC DISTURBANCES**

Do not place power connector cables and other appliances in close proximity of the unit and its cables. Portable and mobile communication devices should not be used in closer proximity of the unit or its cables than the recommended safety distance!

### 3.2.6 Safety Devices on the Unit

The unit can be switched off at the Base module at any time in an emergency (rocker switch on the side of the housing); this will cause no damage to the unit.

### 3.2.7 Condition of the Unit

Irrespective of the faultless manufacture of the unit, damage can occur whilst the unit is in operation. With this in mind, always carry out a visual check of the components mentioned before use. Pay particular attention to crushed cables, damaged tubing, and deformed plugs. If you should notice any damage, please do not use the unit and inform CETONI GmbH without delay. CETONI will return the unit to an operational condition as quickly as possible. Do not attempt to carry out a repair to the unit.

## 3.3 Warranty and Liability

The present unit left our company in perfect condition. The manufacturer is the only entity permitted to open the unit. If the unit is opened by an unauthorised person, all guarantee and liability entitlements, particularly damage entitlements due to personal injuries, are extinguished

The duration of the warranty is 1 year from the day of delivery. It is not extended or renewed due to work carried out under warranty.

CETONI GmbH only considers itself responsible for the unit with regard to safety, reliability and function; if assembly, new-settings, changes, extensions and repairs are carried by CETONI GmbH or an authorised centre, and if the unit has been used in accordance with the instruction manual.

The dosing unit system and the syringe stirrer underlie safety regulation standards. Industrial property rights are reserved on the circuits, methods, names, software programs, and units.

## 3.4 Scope of Supply

The scope of delivery of your neMESYS Base Module should include the following articles:

### **STIRRING MODULE**



### **SYRINGE WITH MOUNTED STIRRER**



### **FOUR DRIVING BELTS**

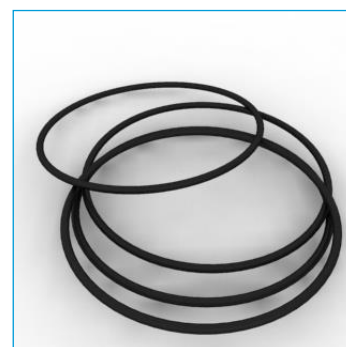

### THREE STIRRERS

(one is mounted in the syringe)



### MOUNTING TOOLS



**IMPORTANT.** The neMIX Syringe Stirrer is usable with the neMESYS Syringe pump system only!

# 4 Technical Specifications

## 4.1 Stirring Module



### 4.1.1 Mechanical Data

<b>DIMENSIONS(L X W X H)</b>	310 x 47 x 56 mm
<b>WEIGHT</b>	≈1000 g
<b>SYRINGE OUTER DIAMETER</b>	max. 14 mm

### 4.1.2 Electrical Data

<b>SUPPLY VOLTAGE</b>	24VDC
<b>CURRENT TYPICAL</b>	0.28 A
<b>CURRENT PEAK</b>	0.33 A

## 4.1.3 Environment

<b>OPERATING TEMPERATURE</b>	0°C to 45°C
<b>STORAGE TEMPERATURE</b>	-40°C bis 75°C
<b>OPERATING HUMIDITY</b>	20% bis 80%, non-condensing
<b>STORAGE HUMIDITY</b>	20% bis 80%, non-condensing
<b>SOUND POWER LEVEL OF THE DEVICE</b>	under 70 dB(A)

## 4.1.4 Dimensions

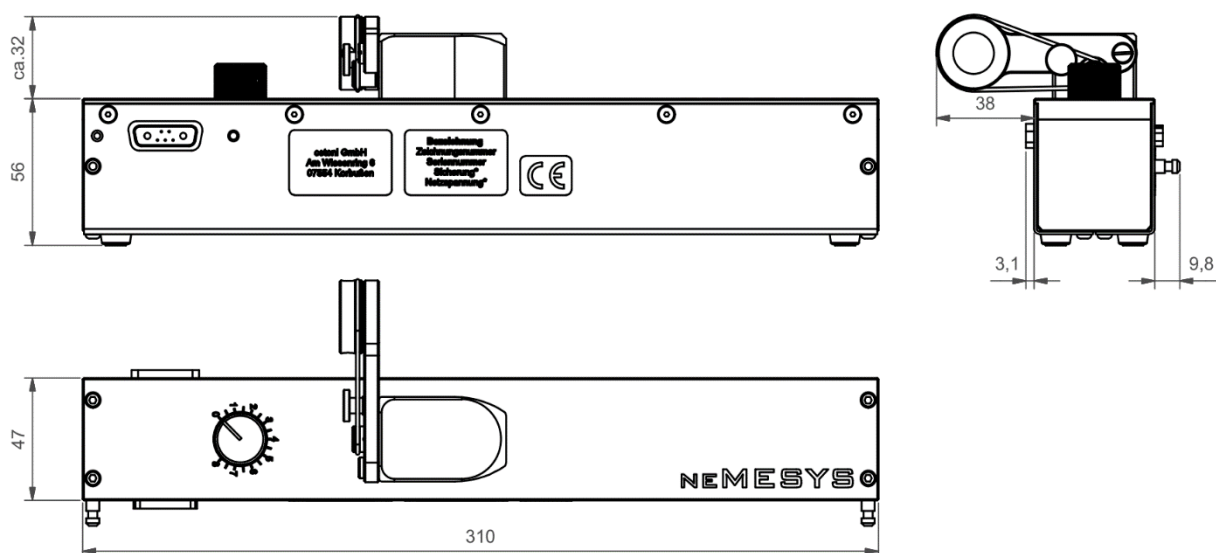

## 4.2 Stirrer Element



### 4.2.1 Technical Data

<b>MATERIALS</b>	FKM tubing (not usable for acetone)
	PTFE
	Epoxy resin (resistant against humidity, oil, thin acids and bases and many solvents)
	Stainless steel 1.4301 (not usable for chlorous mediums and strong acids)
<b>MEDIUM TEMPERATURE</b>	0°C to 100°C
<b>INNER DIAMETER</b>	0,5 mm



**CAUTION.** Danger of damaging the stirrer element! Examine the chemical compatibility of the media you want to process in combination with the listed materials.

## 4.3 Stirring Speed

The stirring speed is adjustable between 15 and 500 rounds per minute. You can take the rotary controller position and the resulting rotary speed from the following chart.

Please be aware that the rotation speed will be limited by the viscosity of the medium. At a certain viscosity value the stirrer element will stand still in the inner of the syringe. In this case please reduce the rotation speed until the stirrer element starts moving again.

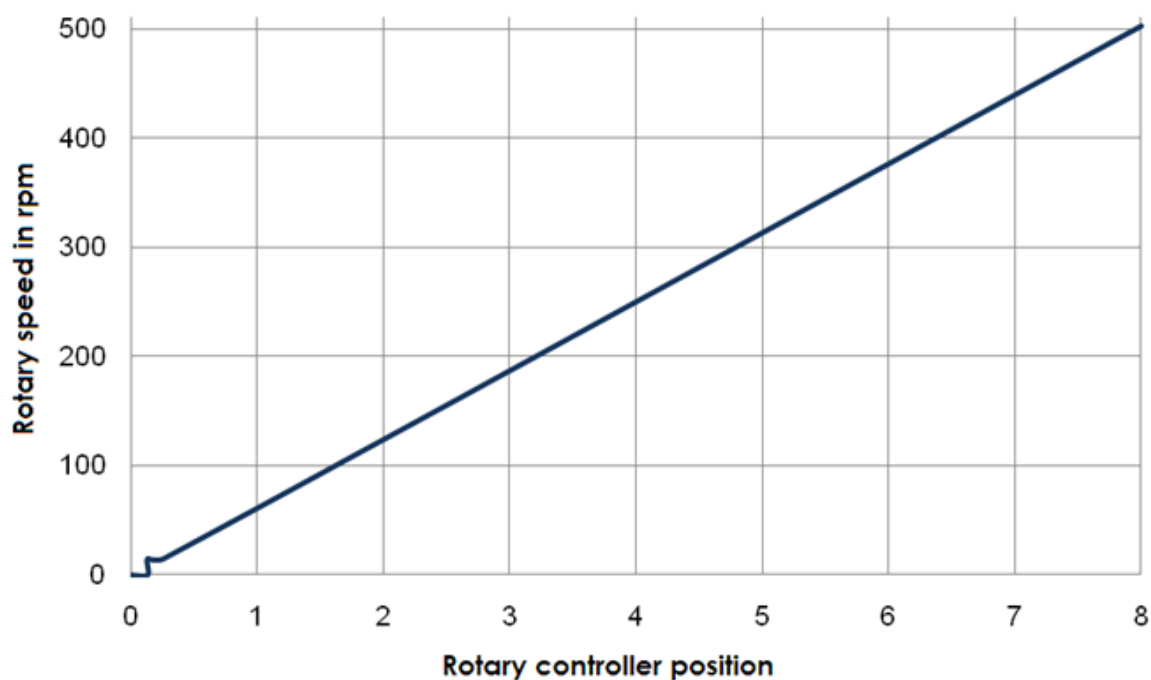



# 5 Transportation and Storage

## 5.1 Transportation

The individual dosing units must not be transported in a plugged-in condition. Plugging together the dosing units serves only to fix the dosing units connected to the dosing platform and does not offer sufficient stability for the transport of multiple combined units. Disassemble the dosing platform into its individual modules prior to transport and re-connect these after transport.

Use only the original packaging designed for the individual modules for transportation or shipping.



**CAUTION.** Risk of damaging the electrical plug connector. Do not transport the modules in a plugged-together condition!

## 5.2 Storage

Observe the information given in the technical data sheets for the operation and storage of the individual modules. (Chapter 4)

# 6 Start-Up

## 6.1 Adding a Stirring Module

Please observe the following steps when adding a stirring module to the neMESYS-syringe pump system:

- (1) Close the software neMESYS User interface.
- (2) Switch the syringe pump system off (switch on the Base module).



**CAUTION.** Danger of data loss through uncontrolled switching off the system. Please do not switch off the syringe pump system as long as the software is still running, except it is an emergency or the software asks you to. If you close the software correctly the adjustments and configuration data will be saved.

- (3) Place the stirring module next to the dosing module of your choice on a flat horizontal base. The locating pins of the dosing module lay opposite the locating hole of the stirring module. In order to guarantee a clean contact between the modules, both modules must lay flat next to each other. Ensure that the modules are not tilted or twisted.

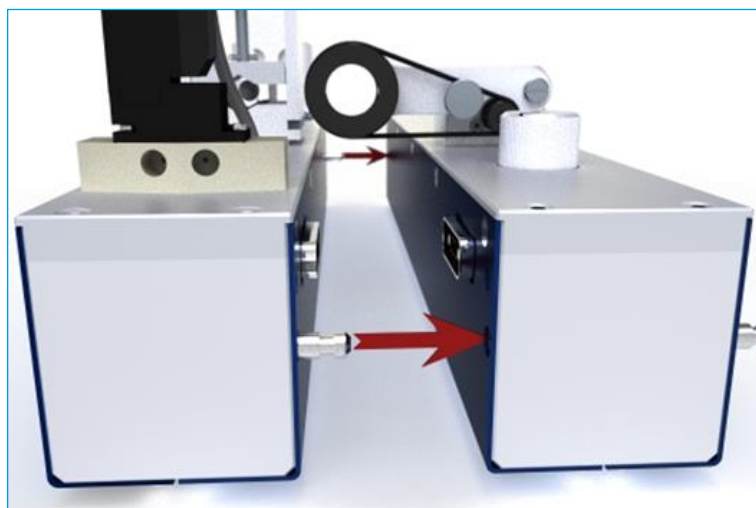

Adding a Stirring Module



**IMPORTANT.** The neMIX Syringe Stirring module will not be detected by the neMESYS User interface. The order of the dosing modules will not be changed no matter on which position the stirring module is connected.

- (4) In case you added the stirring module as a last module please plug the Terminator plug into the according connector.



- (5) Switch the dosing platform on again and start the software. The stirring module is now ready to use.

## 6.2 Removing the Stirring Module

Please follow the following steps in order to remove dosing units from your dosing platform:

- (1) Shut down the software neMESYS User interface.
- (2) Switch the syringe pump system off (by using the main power switch on the base module).
- (3) Remove the stirring module by pulling it off from the system.
- (4) Plug the remaining modules back together and connect the terminator plug the to the last module. The order of the modules will not change because the stirring module is not detected by the software.
- (5) Now you can switch the system on again and work without the stirring module.



**CAUTION.** Risk of damage during separation of the modules through tilting! Please take care while separating the modules that you pull them off as parallel as possible.



**IMPORTANT.** After removing a dosing unit, place the bus terminating plug into the last connected dosing unit again.

# 7 Operation

## 7.1 Mounting and Demounting of the Stirrer

The magnetic stirrer shall be placed into the hole of the Teflon insert and can be replaced by one of the spare stirrers if needed.



**CAUTION.** To remove the stirrer insert later without any problems it is important that the syringe outlet is more than 1.5 mm.

To mount the stirrer insert remove the syringe piston and push the stirrer insert into the syringe to the bottom with the help of the plastics.



Now the piston can be placed back in.

To demount the stirrer insert remove the syringe piston. Than use the steel stick and put it through the outlet of the syringe. Now you can push the stirrer insert until it gets out of the syringe.

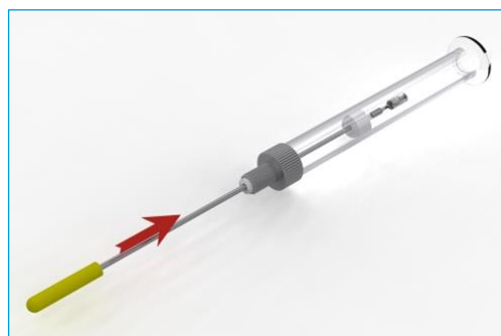

## 7.2 Syringe Clamping

Please observe the following steps when using a stirring syringe and connecting a dosing unit to the stirring module.

- (1) First carry out a reference move with the dosing module that is attached to the stirrer. Right-click on the syringe and choose “Reference Move” in the context menu.

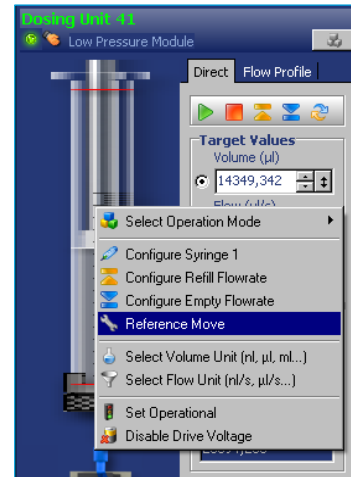

- (2) After finishing the reference move right-click on the syringe again and select “Configure Syringe”.

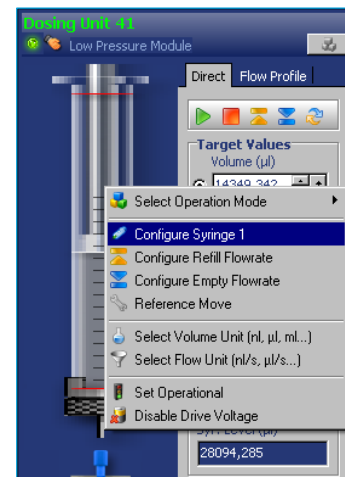

- (3) A dialogue field opens. Please choose “Create”.

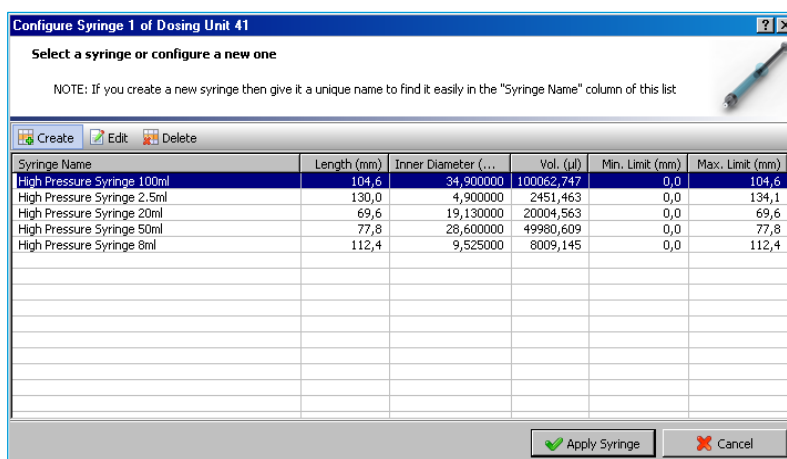

- (4) Enter a unique name for the syringe in the Name field (e.g. neMIX 2,5ml).

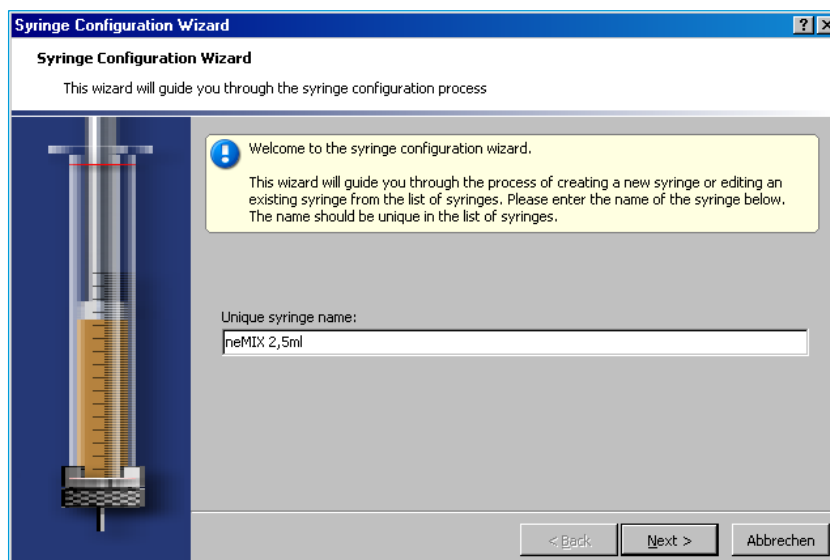

- (5) Define the syringe by choosing scale length and volume.

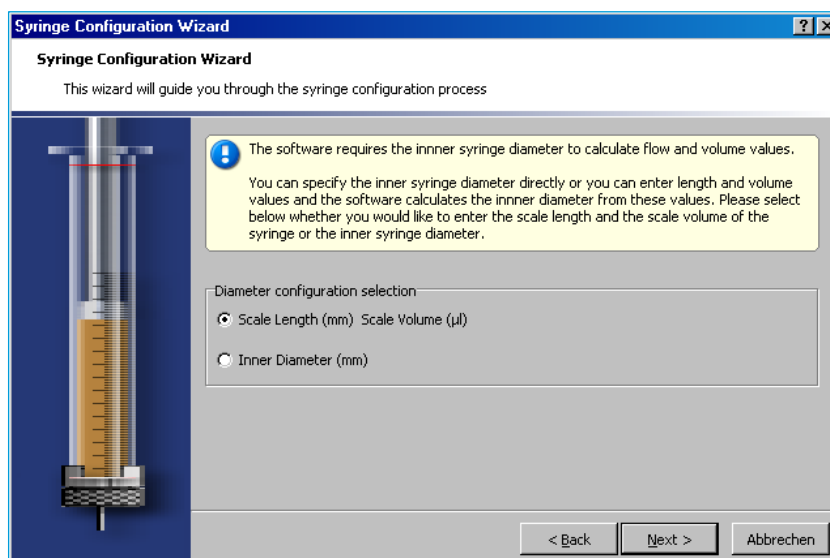

- (6) Normally the nominal volume (syringe size) depends on a 60 mm scale length.

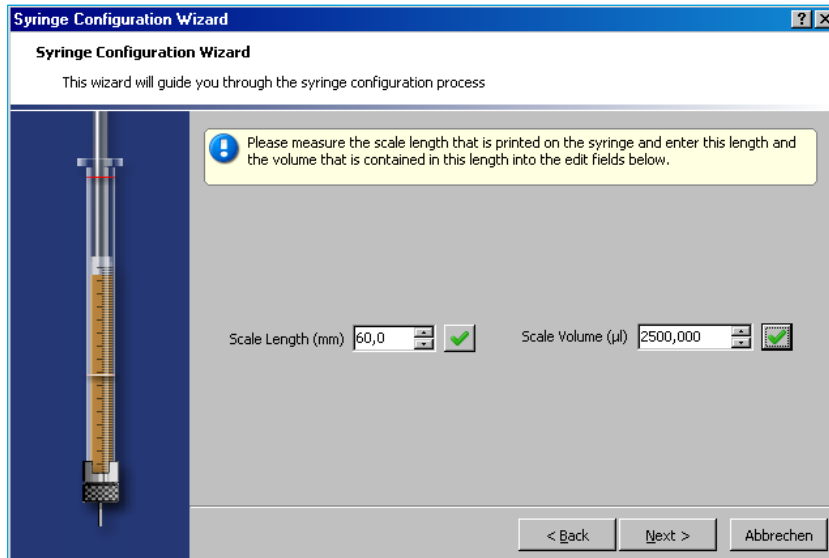

(7) In the next window you can give in the actual syringe stroke.

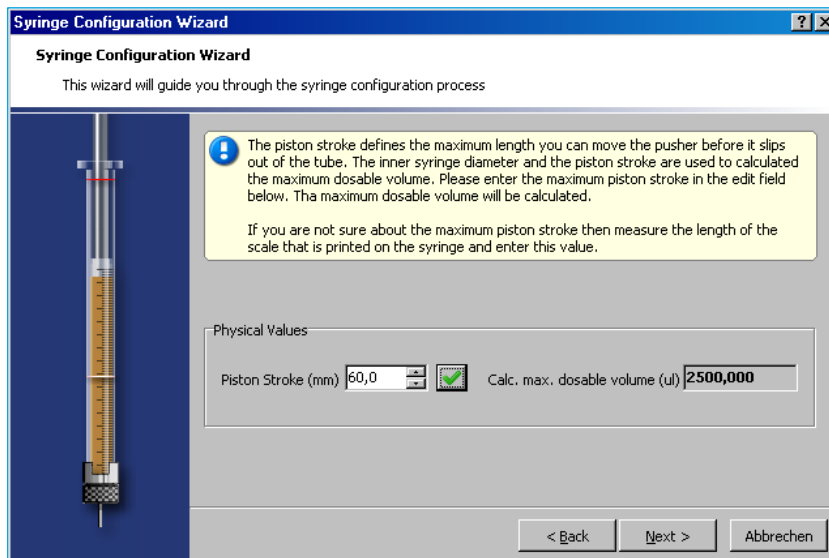

(8) The stirrer insert limits the syringe stroke. Please enter this limit of 25 mm in the next window "Minimum syringe level"

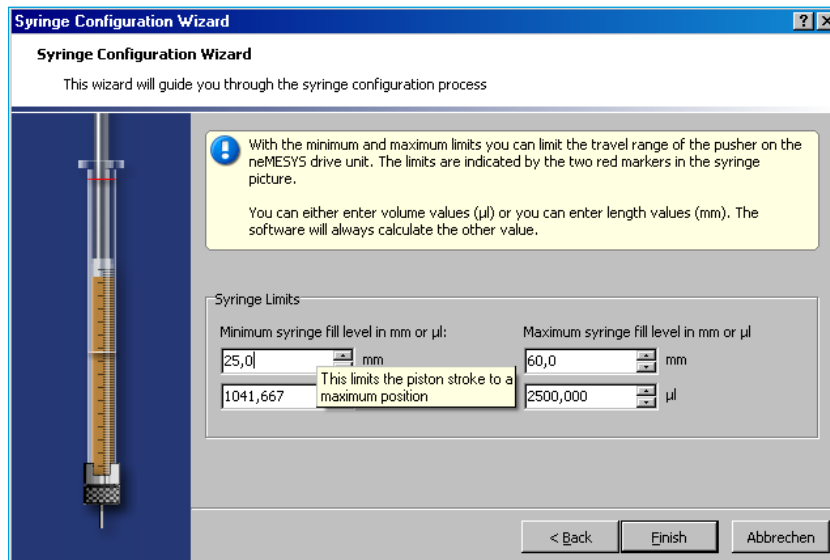

**CAUTION.** Danger of damaging the stirrer insert and syringe Limit the piston stroke of the stirrer related syringe in the software User interface via the syringe configuration to 25 mm!

- (9) The stirring syringe is now fully configured and saved in the syringe list. So you can select it whenever you need. Press “Apply syringe” to use the syringe.

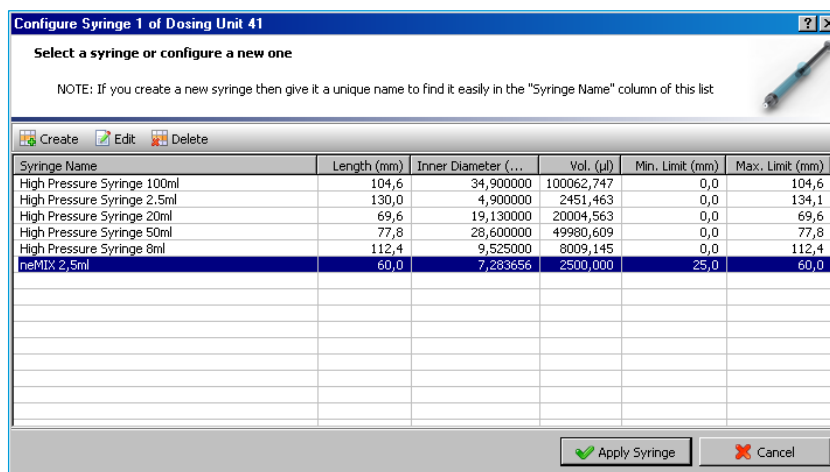



- (10)** By pressing the yellow “Refill” button the piston holder will be brought to the maximum position. Now you can fulfil the next steps to mount the syringe.

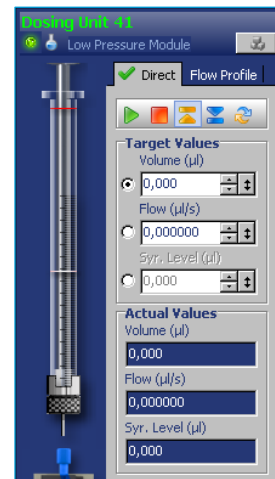

- (11)** Remove the clamp of the syringe holder by losing the knurled screw on top and pushing the clamp to the back. Please take of the piston adapter and the fixing part of the piston holder after losing the knurled screw in the back.

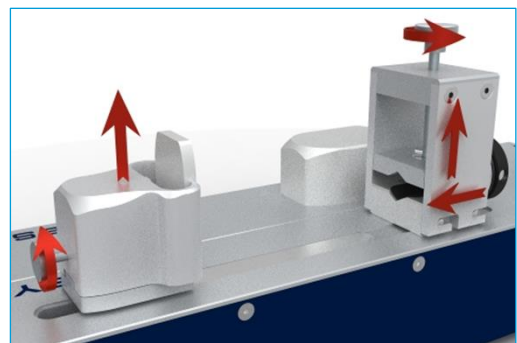

- (12)** Fill the syringe until the maximum and place it on the syringe holder. You can loosen and move the piston holder with a hexagon socket screw key.



- (13)** Move the piston holder in a way that the magnet of the stirrer insert is positioned between the magnets of the driving wheel. To adjust the height of the driving wheel lose the knurled screw (red arrow) and chose the optimal height.



- (14)** Fix the syringe by mounting the syringe holding clamp and fixing the knurled screw. Fix the piston by mounting the fixing part and a suitable piston adapter.

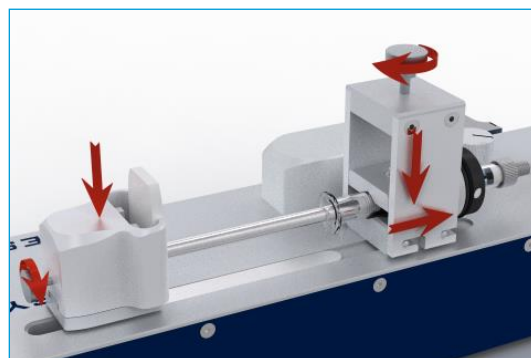

- (15)** By pressing the control dial you can turn the stirring module on and off. By turning the control dial you can chose the individual stirring speed. Please check chapter 4.3 to adjust the suitable stirring speed.

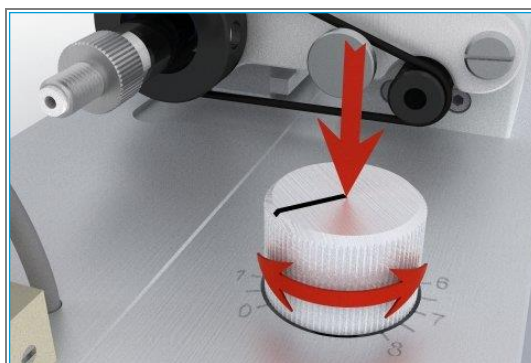

**CAUTION.** Danger of damaging by leaking fluidic connections. Please check the leak tightness of all fluidic connections regularly and after connecting.

# 8 Maintenance and Care

Check the driving belt for abrasion from time to time and change it if required.

The stirring syringe insert can abrade due to the dosed medium and can be exchanged if necessary.

If used in accordance with intended purpose, all the other parts of the device are maintenance-free. The manufacturer recommends sending the devices to CETONI GmbH for maintenance every two years. Should there be a failure despite this, please contact CETONI GmbH.

Please decontaminate the device if necessary and include the completed Declaration of Contamination form in case of a return.

## 8.1 Troubleshooting

If mechanical problems occur, which you cannot eliminate yourself, or which require opening the device, please contact CETONI GmbH to coordinate further actions. The device may only be opened by CETONI GmbH or thereby authorized service staff. Otherwise the warranty and obligation of performance is void.

Software-related troubles are dealt with in the Software Manual.

## 8.2 Cleaning

After use the syringe can be disassembled and the parts can be cleaned with distilled water, ethanol, isopropanol and pressurized air. Storage in alcohol for more than half an hour should be avoided.

Furthermore the syringe and the stirrer insert are autoclavable. Be aware that autoclaving can have a negative influence on the lifetime of the components.

For cleaning it please rub the surface gently with a soft, damp cloth. The cloth must not be wet, so that no fluency can trickle into the device. In case of a heavier soiling you can also use a little bit of detergent or alcohol.

# 9 Disposal

Please return your old devices to CETONI GmbH which will ensure correct disposal according to the Electrical and Electronic Equipment Act.

Please decontaminate the device if necessary and include the completed Declaration of Decontamination form.